

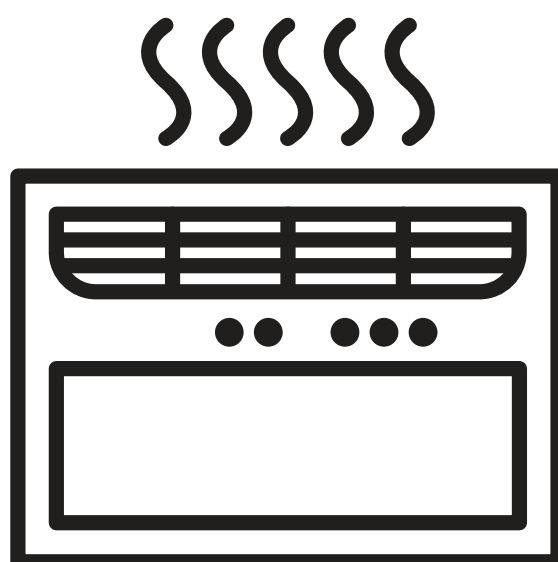

Window type air conditioner

User Manual



BPVOW 090
BPVOW 120

EN

08M-8508803200-0223-01

Please read this user manual first!





Dear Customer,

Thank you for preferring a Grundig product. We hope that you get the best results from your product which has been manufactured with high quality and state-of-the-art technology. Therefore, please read this entire user manual and all other accompanying documents carefully before using the product and keep it as a reference for future use. If you handover the product to someone else, give the user manual as well. Follow all warnings and information in the user manual.

Meanings of the symbols

Following symbols are used in the various section of this manual:

We have provided many important safety messages in this manual and on your appliance. Always read and obey all safety messages.

 Caution, risk of fire	WARNING	[symbol ISO 7010-W021 (2011-05)]	This symbol shows that this appliance uses a flammable refrigerant. If the refrigerant is leaked and exposed to an external ignition source, there is a risk of fire.
	CAUTION	[symbol ISO 7000-0790 (2004-01)]	This symbol shows that the operation manual should be read carefully.
	CAUTION	[symbol ISO 7000-1659 (2004-01)]	This symbol shows that a service personnel should be handling this equipment with reference to the installation manual.
	CAUTION	[symbol ISO 1641-0790 (2004-01)]	This symbol shows that information is available such as the operating manual or installation manual.



DANGER: This symbol alerts you to a potential hazard, that if not avoided, will result in death or serious injury.



WARNING: This symbol alerts you to a potential hazard, that if not avoided, could result in death or serious injury.



CAUTION: This symbol alerts you to a potential hazard, that if not avoided, may result in minor or moderate injury.



Compliance with the WEEE Directive and Disposing of the Waste Product:

This product complies with EU WEEE Directive (2012/19/EU). This product bears a classification symbol for waste electrical and electronic equipment (WEEE).

This symbol indicates that this product shall not be disposed with other household wastes at the end of its service life. Used device must be returned to official collection point for recycling of electrical and electronic devices. To find these collection systems please contact to your local authorities or retailer where the product was purchased. Each household performs important role in recovering and recycling of old appliance. Appropriate disposal of used appliance helps prevent potential negative consequences for the environment and human.

Table of Contents

Safety Information	2
Important Safety Instructions	6
Disposing of the Unit	6
Pre-Installation	7
Electrical requirements	7
Recommended Grounding Method	7
Wiring requirement	7
Hardware Included	7
Unpack the Air Conditioner	8
Location Requirements	8
Dimensions Measurements	9
Installation	10
Operation.....	11
ON/OFF Settings.....	11
Mode Settings.....	12
Temperature Settings.....	12
Fan Speeds.....	12
Timer, Sleep, Filter Functions.....	12
Insert The Batteries.....	13
Quiet.....	15
Super.....	15
Filter.....	15
Dimmer.....	15
Sleep.....	15
Timer.....	16
Changing Air Direction	16
Exhaust Air Vent.....	17
Normal Sounds.....	17
Care and Cleaning	18
Cleaning the Air Filter	18
Cleaning the Front Panel	18
Repairing Paint Damage	18
Annual Maintenance	18
Removing AC From Window	18
Troubleshooting	19
Specification	24

Safety Information

Precautions for using R32 refrigerant The basic installation work procedures are the same as the conventional refrigerant (R22 or R410A). However, pay attention to the following points:

1. Transport of equipment containing flammable refrigerants Compliance with the transport regulations.
2. Marking of equipment using signs Compliance with local regulations.
3. Disposal of equipment using flammable refrigerants Compliance with national regulations.
4. Storage of equipment/appliances The storage of equipment should be in accordance with the manufacturer's instructions.

5. Storage of packed (unsold) equipment

Storage package protection should be constructed such that mechanical damage to the equipment inside the package will not cause a leak of the refrigerant charge.

The maximum number of pieces of equipment permitted to be stored together will be determined by local regulations.

6. Information on servicing

6-1 Checks to the area

Prior to beginning work on systems containing flammable refrigerants, safety checks are necessary to ensure that the risk of ignition is minimised. For repair to the refrigerating system, the following precautions shall be complied with prior to conducting work on the system.

6-2 Work procedure

Work shall be undertaken under a controlled procedure so as to minimise the risk of flammable gas or vapour being present while the work is being performed.

6-3 General work area

All maintenance staff and others working in the local area shall be instructed on the nature of work being carried out. Work in confined spaces shall be avoided.

The area around the workspace shall be sectioned off. Ensure that the conditions within the area have been made safe by control of flammable material.

6-4 Checking for presence of refrigerant

The area shall be checked with an appropriate refrigerant detector prior to and during work, to ensure the technician is aware of potentially flammable atmospheres.

Ensure that the leak detection equipment being used is suitable for use with flammable refrigerants, i.e. non-sparking, adequately sealed or intrinsically safe.

6-5 Presence of fire extinguisher

If any hot work is to be conducted on the refrigeration equipment or any associated parts, appropriate fire extinguishing equipment shall be available to hand.

Have a dry powder or CO₂ fire extinguisher adjacent to the charging area.

6-6 No ignition sources

No person carrying out work in relation to a refrigeration system which involves exposing any pipe work that contains or has contained flammable refrigerant shall use any sources of ignition in such a manner that it may lead to the risk of fire or explosion.

All possible person ignition sources, including cigarette smoking, should be kept sufficiently far away from the site of installation, repairing, removing and disposal, during which flammable refrigerant can possibly be released to the surrounding space.

Prior to work taking place, the area around the equipment is to be surveyed make sure that there are no flammable hazards or ignition risks. "No Smoking" signs shall be displayed.

6-7 Ventilated area

Ensure that the area is in the open or that it is adequately ventilated before breaking into the system or conducting any hot work.

A degree of ventilation shall continue during the period that the work is carried out.

The ventilation should safely disperse any released refrigerant and preferably expel it externally into the atmosphere.

6-8 Checks to the refrigeration equipment

Where electrical components are being changed, they shall be fit for the purpose and to the correct specification.

Safety Information

At all times the manufacturer's maintenance and service guidelines shall be followed. If in doubt consult the manufacturer's technical department for assistance.

The following checks shall be applied to installations using flammable refrigerants:

- The ventilation machinery and outlets are operating adequately and are not obstructed;
- If an indirect refrigerating circuit is being used, the secondary circuit shall be checked for the presence of refrigerant;
- Marking to the equipment continues to be visible and legible. Markings and signs that are illegible shall be corrected;
- Refrigeration pipe or components are installed in a position where they are unlikely to be exposed to any substance which may corrode refrigerant containing components, unless the components are constructed of materials which are inherently resistant to being corroded or are suitably protected against being so corroded.

6-9 Checks to electrical devices

Repair and maintenance to electrical components shall include initial safety checks and component inspection procedures.

If a fault exists that could compromise safety, then no electrical supply shall be connected to the circuit until it is satisfactorily dealt with.

If the fault cannot be corrected immediately but it is necessary to continue operation, an adequate temporary solution shall be used.

This shall be reported to the owner of the equipment so all parties are advised. Initial safety checks shall include:

- That capacitors are discharged: this shall be done in a safe manner to avoid possibility of sparking;
- That there are no live electrical components and wiring are exposed while charging, recovering or purging the system;
- That there is continuity of earth bonding.

7. Repairs to sealed components

During repairs to sealed components, all electrical supplies shall be disconnected from the equipment being worked upon prior to any removal of sealed covers, etc.

If it is absolutely necessary to have an electrical supply to equipment during servicing, then a permanently operating form of leak detection shall be located at the most critical point to warn of a potentially hazardous situation.

Particular attention shall be paid to the following to ensure that by working on electrical components, the casing is not altered in such a way that the level of protection is affected.

This shall include damage to cables, not made to original specification, damage to seals, incorrect fitting of glands, etc. Ensure that apparatus is mounted securely.

Ensure that seals or sealing materials have not degraded such that they no longer serve the purpose of preventing the ingress of flammable atmospheres.

Replacement parts shall be in accordance with the manufacturer's specifications. NOTE:

The use of silicon sealant may inhibit the effectiveness of some types of leak detection equipment. Intrinsically safe components do not have to be isolated prior to working on them.

8. Repair to intrinsically safe components

Do not apply any permanent inductive or capacitance loads to the circuit without ensuring that this will not exceed the permissible voltage and current permitted for the equipment in use.

Intrinsically safe components are the only types that can be worked on while live in the presence of a flammable atmosphere. The test apparatus shall be at the correct rating.

Replace components only with parts specified by the manufacturer. Other parts may result in the ignition of refrigerant in the atmosphere from a leak.

9. Cabling

Check that cabling will not be subject to wear, corrosion, excessive pressure, vibration, sharp edges or any other adverse environmental effects.

The check shall also take into account the effects of aging or continual vibration from sources such as compressors or fans

10. Detection of flammable refrigerants

Under no circumstances shall potential sources of ignition be used in the searching for or detection of refrigerant leaks.

A halide torch (or any other detector using a naked flame) shall not be used.

Safety Information

11. Leak detection methods

- The following leak detection methods are deemed acceptable for systems containing flammable refrigerants:
 - Electronic leak detectors shall be used to detect flammable refrigerants, but the sensitivity may not be adequate, or may need re-calibration. (Detection equipment shall be calibrated in a refrigerant-free area.)
 - Ensure that the detector is not a potential source of ignition and is suitable for the refrigerant used.
 - Leak detection equipment shall be set at a percentage of the LFL of the refrigerant and shall be calibrated to the refrigerant employed and the appropriate percentage of gas (25 % maximum) is confirmed. Leak detection fluids are suitable for use with most refrigerants but the use of detergents containing chlorine shall be avoided as the chlorine may react with the refrigerant and corrode the copper pipe-work.
 - If a leak is suspected, all naked flames shall be removed/ extinguished.
 - If a leakage of refrigerant is found which requires brazing, all of the refrigerant shall be recovered from the system, or isolated (by means of shut off valves) in a part of the system remote from the leak.
 - Oxygen free nitrogen (OFN) shall then be purged through the system both before and during the brazing process.

12. Removal and evacuation

- When breaking into the refrigerant circuit to make repairs-or for any other purpose- conventional procedures shall be used.
- However, it is important that best practice is followed since flammability is a consideration.
- The following procedures shall be adhered to:
 - Remove refrigerant;-Purge the circuit with inert gas;
 - Evacuate;-Purge again with inert gas;
 - Open the circuit by cutting or brazing.
- The refrigerant charge shall be recovered into the correct recovery cylinders. The system shall be "flushed" with OFN to render the unit safe.
- This process may need to be repeated several times.
- Compressed air or oxygen shall not be used for this task.
- Flushing shall be achieved by breaking the vacuum in the system with OFN and continuing to fill until the working pressure is achieved, then venting to atmosphere, and finally pulling down to a vacuum.
- This process shall be repeated until no refrigerant is within the system. When the final OFN charge is used, the system shall be vented down to atmospheric pressure to enable work to take place.
- This operation is absolutely vital if brazing operations on the pipe-work are to take place.
- Ensure that the outlet for the vacuum pump is not close to any ignition sources and there is ventilation available.

13. Charging procedures

- In addition to conventional charging procedures, the following requirements shall be followed:
- Ensure that contamination of different refrigerants does not occur when using charging equipment.
 - Hoses or lines shall be as short as possible to minimise the amount of refrigerant contained in them.
 - Cylinders shall be kept upright.
 - Ensure that the refrigeration system is earthed prior to charging the system with refrigerant.
 - Label the system when charging is complete (if not already).
 - Extreme care shall be taken not to overfill the refrigeration system.
 - Prior to recharging the system it shall be pressure tested with OFN.
 - The system shall be leak tested on completion of charging but prior to commissioning.
 - A follow up leak test shall be carried out prior to leaving the site.

14. Decommissioning

- Before carrying out this procedure, it is essential that the technician is completely familiar with the equipment and all its detail.
 - It is recommended good practice that all refrigerants are recovered safely.
 - Prior to the task being carried out, an oil and refrigerant sample shall be taken in case analysis is required prior to re-use of reclaimed refrigerant. It is essential that electrical power is available before the task is commenced.
- a) Become familiar with the equipment and its operation.
 - b) Isolate system electrically.

Safety Information

- c) Before attempting the procedure ensure that:
- Mechanical handling equipment is available, if required, for handling refrigerant cylinders;
 - All personal protective equipment is available and being used correctly;
 - The recovery process is supervised at all times by a competent person;
 - Recovery equipment and cylinders conform to the appropriate standards.
- d) Pump down refrigerant system, if possible.
- e) If a vacuum is not possible, make a manifold so that refrigerant can be removed from various parts of the system.
- f) Make sure that cylinder is situated on the scales before recovery takes place.
- g) Start the recovery machine and operate in accordance with manufacturer's instructions.
- h) Do not overfill cylinders. (No more than 80 % volume liquid charge).
- i) Do not exceed the maximum working pressure of the cylinder, even temporarily.
- j) When the cylinders have been filled correctly and the process completed, make sure that the cylinders and the equipment are removed from site promptly and all isolation valves on the equipment are closed off.
- k) Recovered refrigerant shall not be charged into another refrigeration system unless it has been cleaned and checked.

15. Labelling

- Equipment shall be labelled stating that it has been de-commissioned and emptied of refrigerant.
- The label shall be dated and signed.
- Ensure that there are labels on the equipment stating the equipment contain flammable refrigerant.

16. Recovery

- When removing refrigerant from a system, either for servicing or decommissioning, it is recommended good practice that all refrigerants are removed safely.
- When transferring refrigerant into cylinders, ensure that only appropriate refrigerant recovery cylinders are employed. Ensure that the correct number of cylinders for holding the total system charge is available.
- All cylinders to be used are designated for the recovered refrigerant and labelled for that refrigerant (i.e. special cylinders for the recovery of refrigerant).
- Cylinders shall be complete with pressure relief valve and associated shut-off valves in good working order.
- Empty recovery cylinders are evacuated and, if possible, cooled before recovery occurs.
- The recovery equipment shall be in good working order with a set of instructions concerning the equipment that is at hand and shall be suitable for the recovery of flammable refrigerants.
- In addition, a set of calibrated weighing scales shall be available and in good working order. Hoses shall be complete with leak-free disconnect couplings and in good condition. Before using the recovery machine, check that it is in satisfactory working order, has been properly maintained and that any associated electrical components are sealed to prevent ignition in the event of a refrigerant release.
- Consult manufacturer if in doubt. The recovered refrigerant shall be returned to the refrigerant supplier in the correct recovery cylinder, and the relevant Waste Transfer Note arranged.
- Do not mix refrigerants in recovery units and especially not in cylinders.
- If compressors or compressor oils are to be removed, ensure that they have been evacuated to an acceptable level to make certain that flammable refrigerant does not remain within the lubricant.
- The evacuation process shall be carried out prior to returning the compressor to the suppliers.
- Only electric heating to the compressor body shall be employed to accelerate this process.
- When oil is drained from a system, it shall be carried out safely.
- When moving or relocating the air conditioner, consult experienced service technicians for disconnection and reinstallation of the unit.
- Do not place any other electrical products or household belongings under indoor unit or outdoor unit. Condensation dripping from the unit might get them wet, and may cause damage or malfunction of your property.
- Do not use means to accelerate the defrosting process or to clean, other than those recommended by the manufacturer.
- The appliance shall be stored in a room without continuously operating ignition sources (for example, open flames, an operating gas appliance or an operating electric heater).
- Do not pierce or burn. Be aware that refrigerants may not contain an odor.
- To keep ventilation openings clear of obstruction.

Safety Information

- The appliance shall be stored in a well-ventilated area where the room size corresponds to the room area as specified for operation.
- The appliance shall be stored in a room without continuously operating open flames (for example an operating gas appliance) and ignition sources (for example an operating electric heater).
- Any person who is involved with working on or breaking into a refrigerant circuit should hold a current valid certificate from an industry-accredited assessment authority, which authorises their competence to handle refrigerants safely in accordance with an industry recognised assessment specification.
- Servicing shall only be performed as recommended by the equipment manufacturer.
- Maintenance and repair requiring the assistance of other skilled personnel shall be carried out under the supervision of the person competent in the use of flammable refrigerants.
- Do not use means to accelerate the defrosting process or to clean, other than those recommended by the manufacturer.
- Appliance shall be installed, operated and stored in a room with a floor area larger than 10 m².
- The installation of pipe-work shall be kept to a room with a floor area larger than 10 m².
- The pipe-work shall be complied with national gas regulations.
- The maximum refrigerant charge amount is 2.5 kg. The specific refrigerant charge is based on the nameplate of the outdoor unit.
- Mechanical connectors used indoors shall comply with ISO 14903. When mechanical connectors are reused indoors, sealing parts shall be renewed. When flared joints are reused indoors, the flare part shall be re-fabricated.
- The installation of pipe-work shall be kept to a minimum.
- Mechanical connections shall be accessible for maintenance purposes.

IMPORTANT SAFETY INSTRUCTIONS

To reduce the risk of fire, electrical shock or injury when using your air conditioner, follow these basic precautions:

- Plug into a grounded 3-prong outlet.
- Do not remove ground prong.
- Do not use an adapter.
- Do not use an extension cord.
- Unplug air conditioner before servicing.
- Use two or more people to move and install air conditioner.

DISPOSING OF THE UNIT

- Before throwing out the device, it is necessary to remove the battery cells and dispose or recycle them properly.
- When you need disposal of the unit consult our dealer. If pipes are removed incorrectly, refrigerant may blow out and come into contact with your skin, causing injury. Releasing refrigerant into the atmosphere also damages the environments.
- Please recycle or dispose of the product packaging material in an environmentally responsible manner.
- Never store or ship the air conditioner upside down or sideways to avoid damage to the compressor.
- This appliance is not intended for use by persons (including children) with reduced physical, sensory or mental capabilities, or lack of experience and knowledge, unless they have been given supervision or instruction concerning use of the appliance by a person responsible for their safety. Children should be supervised to ensure that they do not play with the appliance.
- The wiring diagram is shown on nameplate on the air conditioner.

Pre-Installation

ELECTRICAL REQUIREMENTS

WARNING: Electrical Shock Hazard



- Plug into a grounded 3-prong outlet.
- Do not remove ground prong.
- Do not use an adapter.
- Do not use an extension cord.
- Failure to follow these instructions can result in death, fire, or electrical shock.



RECOMMENDED GROUNDING METHOD

This air conditioner must be grounded. This air conditioner is equipped with a power supply cord with a three-prong grounding plug. The cord must be plugged into a three-prong outlet, grounded in accordance with all local codes and ordinances. If a grounded outlet is not available, it is the customer's responsibility to have a properly grounded three-prong outlet installed by a qualified electrical installer. It is the customer's responsibility:

- To contact a qualified electrical installer.
- To assure that the electrical installation is adequate and conforms to the Nation Electrical Code, ANSI/NFPA 70-last edition, and all local codes and ordinances.

WIRING REQUIREMENT

Power supply	Model	Time-delay fuse (or circuit breaker)
230V	BPVOW 090 BPVOW 120	13A

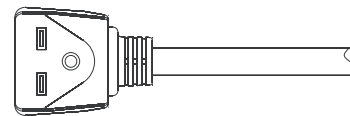
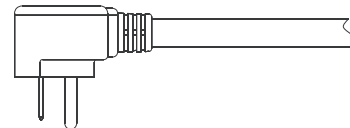

NOTE:
Your air conditioner's device may differ from the one shown. This room air conditioner is equipped with a power supply cord required by UL.

HARDWARE INCLUDED



NOTE: Check that all parts are included in parts package.

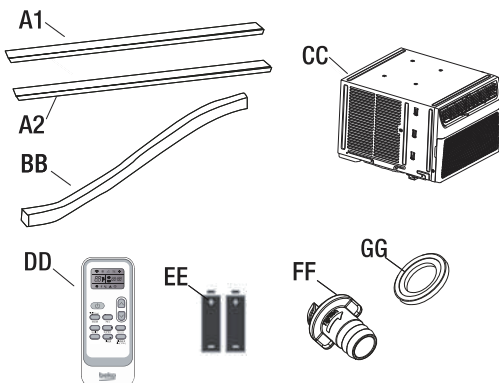

Part	Description	Quantity
A1	Adhesive seal (gray)	2
A2	Adhesive seal (black)	2
BB	Foam seal	2
CC	Air conditioner	1
DD	Remote control	1
EE	Batteries (standard AAA 1.5 Volt)	2
FF	Drain connector	1
GG	Seal Gasket	1

Pre-Installation

UNPACK THE AIR CONDITIONER



WARNING: Excessive Weight Hazard
Use two or more people to move and install air conditioner.
Failure to do so can result in back or other injury.

Remove packaging materials

- Remove and dispose of/recycle packaging materials. Remove tape and glue residue from surfaces before turning on the air conditioner. Rub a small amount of liquid dish soap over the adhesive with your fingers. Wipe with warm water and dry.
- Do not use sharp instruments, rubbing alcohol, flammable fluids, or abrasive cleaners to remove tape or glue. These products can damage the surface of your air conditioner.
- Handle the air conditioner gently.

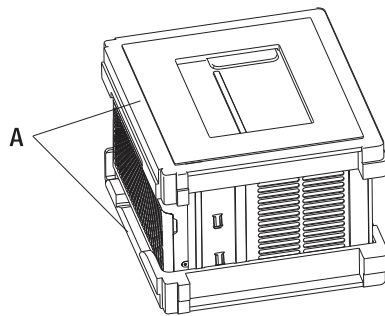

LOCATION REQUIREMENTS

Before you Begin

Read these instructions completely and carefully.



IMPORTANT:

- Save these instructions for local inspector's use.
- Observe all governing codes and ordinances.



NOTE: Installer, be sure to leave these instructions with the Consumer.



NOTE: Consumer, keep these instructions for future reference.

- Skill level:** Installation of this appliance requires basic mechanical skills.
- Completion time:** Approximately half an hour.
- We recommend that two people install this product.
- Proper installation is the responsibility of the installer.
- Product failure due to improper installation is not covered under the warranty.
- You **MUST** use all supplied parts and use proper installation procedures as described in these instructions when installing this air conditioner.



IMPORTANT: Observe all governing codes and ordinances.

Pre-Installation

Check the location where air conditioner will be installed. Proper installation is your responsibility. Make sure you have everything necessary for correct installation.

The location should provide:

- Do not use an extension cord. The appliance shall be installed in accordance with national wiring regulations.
- Free movement of air in room to be cooled.
- A large enough opening for the air conditioner.



NOTE: Cabinet louvers (A) must not be obstructed. Air must be able to pass freely through the cabinet louvers.

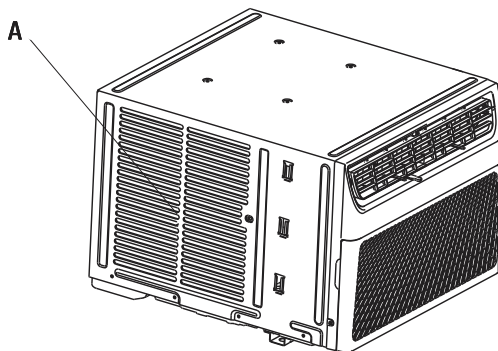

DIMENSIONS MEASUREMENTS

- The electrical outlet must be within reach of the power cord.
- Follow the dimensions in the table for your model.
- The size of the mounting hole must be larger than the size of the unit.

Models	A	B
BPVOW 090 BPVOW 120	14 4/5 inch (376 mm)	19 1/4 inch (488 mm)

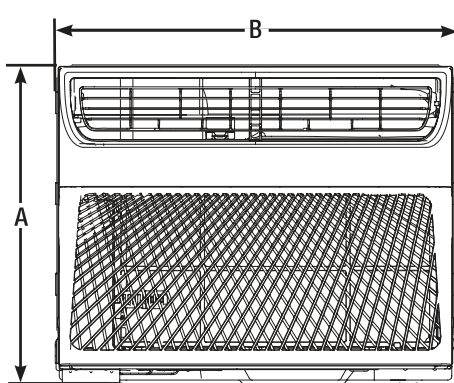

Installation

1 Placing Air Conditioner



WARNING: Excessive Weight Hazard

- Use two or more people to move and install air conditioner.
- Failure to do so can result in back or other injury.



NOTES:

- Handle air conditioner gently.
- Be sure your air conditioner does not fall out of the opening during installation or removal.
- Do not block the louvers in the front panel.
- Do not block the louvers on the outside of the air conditioner.
- Your model may differ from the one shown.

- Keeping a firm grip on the air conditioner, carefully place the unit into the mounting hole or window with a mounting bracket (A).

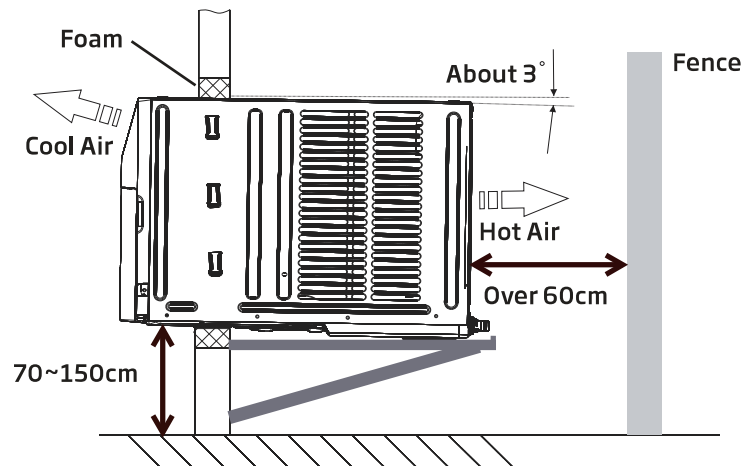

2 Completing Installation

- Check the gap (B) around the unit and seal it with the adhesive seal or foam seal attached.

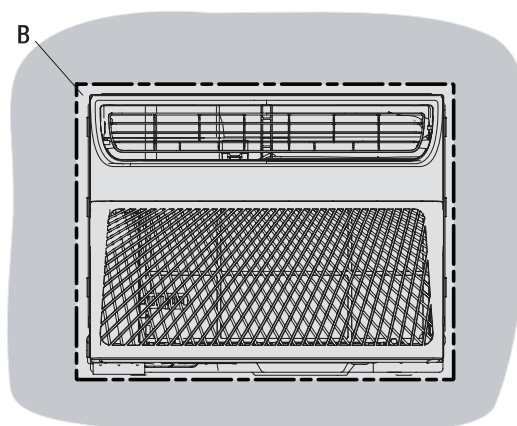

Operation

AIR CONDITIONER USE

IMPORTANT:



- If you turn off the air conditioner, wait at least 3 minutes before turning it back on. This prevents the air conditioner from blowing a fuse or tripping a circuit breaker.
- Air conditioner in the Cool mode operation the better limits: Outdoor 64.4-109.4°F (18-43 °C), ≤ 80% RH; indoor 62.6-89.6°F (17-32°C), ≤ 80% RH.
- Air conditioner in the Heat mode operation the better limits: Outdoor 19.4-75.2°F (-7-24 °C), ≤ 80% RH; indoor 32-80.6°F (0-27°C), ≤ 80% RH.
- In the event of a power failure, your air conditioner will operate at the previous settings when the power is restored.

- Operating your air conditioner properly helps you to obtain the best possible results.
- This section explains proper air conditioner operation.

1 Using the Control Panel



ON/OFF

ON/ OFF SETTINGS

- Press the power button to turn on the air conditioner.



NOTE: When the air conditioner is turned on for the first time after it is plugged in, the display will show the current set temperature and will run in the ECO control. After cleaning and replacing the filter, press the POWER button for resetting and the FILTER light will go off.

- Select mode. See "Mode Settings" on page 12.
- Set temperature. See "Temperature Settings" on page 12.
- Select fan speed. See "Fan Speeds" on page 12.

Operation

• Fan • Dry • Cool • Eco



MODE

MODE SETTINGS





- Press MODE repeatedly until you see the indicator light glow for the desired setting.
- Choose Fan, Dry, Cool, Eco.
- FAN - To select Fan Only mode.
- Dry - Dries the room. The air conditioner automatically selects the temperature. Fan runs at Low speed only.
- Cool - Cools the room.
- Eco - Cools the room and saves energy.



NOTE : Dry mode should not be used to cool the room.



TEMPERATURE SETTINGS

- Press the plus UP  button to raise the temperature. Each time you press or hold the plus UP  button, the temperature will go up 1 °F (1 °C) until it reaches 86°F (30°C).
- Press the minus DOWN  button to lower the temperature. Each time you press or hold the DOWN  button, the temperature will go down 1 °F (1 °C) until it reaches 61 °F (16°C).
- To change the temperature display from °F to °C: Press both the MODE and DOWN  buttons at the same time for 5 seconds to switch the display from °F to °C.

• Low • Med • High



FAN

FAN SPEEDS



NOTE: The Fan button will operate only when the Fan, Cool or ECO mode has been selected.

- Press FAN until you see the indicator light glow for the desired setting.
- Choose High, Med, Low.
- High - for maximum cooling
- Med - for normal cooling
- Low - for quieter cooling



NOTE: In ECO mode, the Fan will run at low speed when compressor turns off.

• Timer • Sleep • Filter



TIMER, SLEEP, FILTER FUNCTIONS

- The LED light on control panel for Timer, Sleep, Filter.
- For function operation, see "Using the Remote Control."

2 Using the Remote Control

INSERT THE BATTERIES

- Remove the battery cover along the arrow direction.
- Insert new batteries making sure that the (+) and (-) of battery are matched correctly.

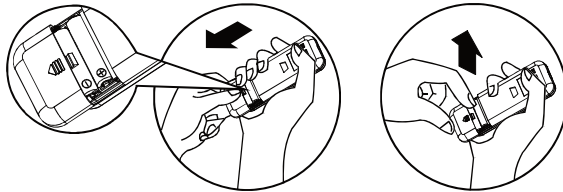

- Re-attach the cover by sliding it back into position.



NOTE:

- Use 2 standard AAA (1.5 volt) batteries. Do not use rechargeable batteries.
- Replace batteries with new ones of the same type when the display becomes dim, or after 6 months.
- When replacing batteries, always replace both batteries with new batteries. Do not mix old and new batteries. Do not mix alkaline, standard(carbon-zinc), or rechargeable (ni-cd, ni-mh, etc) batteries.
- If the air conditioner will not be used for an extended period of time, remove the batteries from the remote.



- Do not use the remote if the batteries have leaked. The chemicals in batteries could cause burns or other health hazards.
- Do not dispose of batteries in a fire. Batteries may explode or leak.

Operation

HOW TO USE

□ To operate the room air conditioner, aim the remote control at the signal receptor. The remote control will operate the air conditioner at a distance of up to 23' (7m) when pointed at the signal receptor.

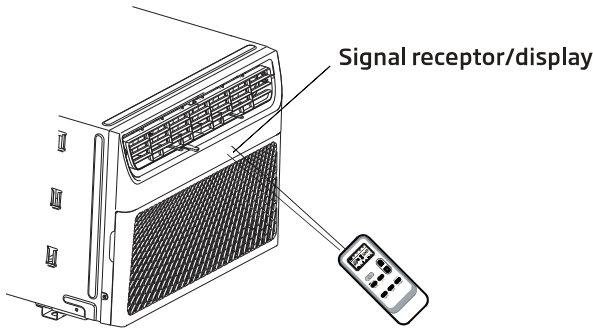

INDICATION SYMBOLS

Cooling Indicator	Auto fan speed
Dry indicator	High fan speed
Fan only indicator	Medium fan speed
Heating Indicator	Low fan speed
Quiet indicator	Sleep Indicator
Signal transmit	

ON		Display set timer
OFF		Display current time
		Display temperature

Button AND FUNCTION



NOTE: Remote control may differ in appearance. Swing function is not available on this models.

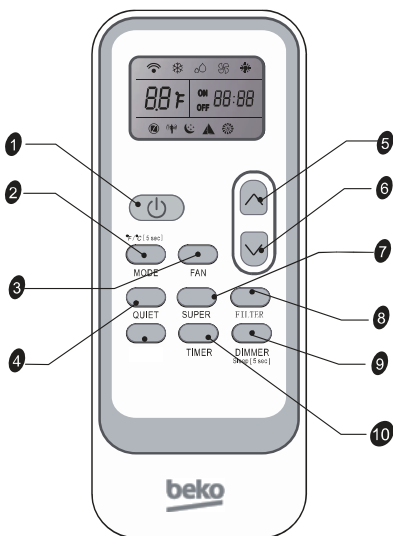

1		ON/ OFF	5		UP
2		MODE	6		DOWN
3		FAN	7		SUPER
4		QUIET	8		FILTER
			9		DIMMER or SLEEP
			10		TIMER ON/ OFF



NOTE: Press and hold the MODE button on the remote for 5 seconds to switch the temperature display from degrees Fahrenheit (°F) to degrees Celsius (°C).

Operation



QUIET

QUIET

- Press the Quiet button to set or cancel the Quiet Mode operation.



NOTE:

- It takes about 2 to 3 minutes to fully enter the quiet mode.
- Sometimes it cannot enter the quiet mode because of some protection.



SUPER

Fast cooling



SUPER

The SUPER button is used to start or stop fast cooling.

- Press the SUPER button. The air conditioner automatically sets the fan speed to High and the temperature to 16°C.
- To turn off Super control, press any button on the remote control or control panel except Timer, Clock, Dimmer, and Swing.



NOTE: In the SUPER mode, you can set the timer.



FILTER

FILTER

- When the Filter indicator light is lit, remove, clean and replace the air filter. See "Cleaning the Air Filter".
- Press Power button on the machine or FILTER button on remote to reset the filter after cleaning and replacing the air filter.



NOTE: When the light is on, it will remain on for 180 hours or until you press Clean Filter button.



DIMMER
Sleep [5 sec]

DIMMER

- Press the DIMMER button to turn off the control panel display.



NOTE: When in DIMMER mode, new control inputs will return display to normal.



DIMMER
Sleep [5 sec]

SLEEP

The SLEEP mode can be set in Cool, Dry or ECO mode. When in sleep mode, the unit will utilize lower, quieter fan speeds and automatic temperature adjustments offering 8 hours of optimal sleeping conditions before shutting off.

- Press MODE to select Cool, Dry or ECO.



NOTE: Sleep control cannot be selected in Fan mode.

- Press the up or down arrow button to set the temperature.
- Press and hold the DIMMER button on the remote for 5 seconds to switch the DIMMER mode to SLEEP mode.
- After 10 seconds, the light on the control panel display will dim.

Operation

- To turn off Sleep control, press MODE, FAN, SLEEP or wait 8 hours for Sleep control to turn off automatically.



NOTE: When you press sleep button:

- The appliance will stop operation automatically after operating for 8 hours.
- Fan speed is automatically set at low speed.
- In the Cooling mode, Dry mode, and ECO mode, the set temperature will increase by 4°F (2°C) at most, during 2 hours, and continues running at that temperature until auto shut off.



TIMER

TIMER

Setting the Air Conditioner to Turn ON:

- Plug in the air conditioner and use the remote to power it on.
- Use the remote to set the desired mode, temperature, fan speed, etc.
- Use the remote to power off the air conditioner.
- Press TIMER on the remote and use the UP, DOWN buttons to set the desired delay time until the air conditioner turns ON. The delay time can be set from 0 to 24 hours in one-hour increments.
- Press TIMER again to enter the delay time. The TIMER led on the air conditioner illuminates, and the delay time appears on the remote.

Setting the Air Conditioner to Turn OFF:

- Plug in the air conditioner and use the remote to power it on.
- Use the remote to set the desired mode, temperature, fan speed, etc.
- Press TIMER on the remote and use the UP, DOWN buttons to set the desired delay time until the air conditioner turns ON. The delay time can be set from 0 to 24 hours in one-hour increments.
- Press TIMER again to enter the delay time. The TIMER led on the air conditioner illuminates, and the delay time appears on the remote.

To cancel TIMER:

- Press the TIMER button again; when a "Beep" is heard and the indicator disappears, the TIMER mode has been canceled.



NOTE: The TIMER function can only be set using the remote.

3 Changing Air Direction

- Use the Vertical Level Vane (A) to direct the air right or left. Use the whole cartridge (B) to direct air up, down or straight ahead.

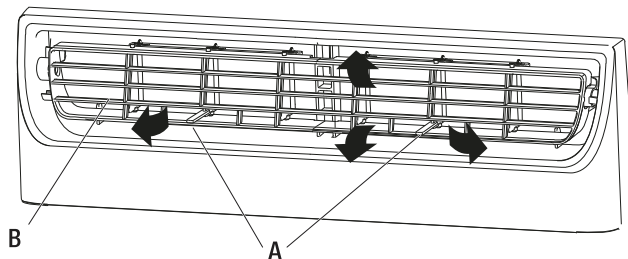

Operation

4 Exhaust Air Vent

- Pull out the exhaust air vent control to Open the exhaust air vent and draw stale or smoky air from the room.
- Push in the exhaust air vent control to close the exhaust air vent for maximum continuous cooling.

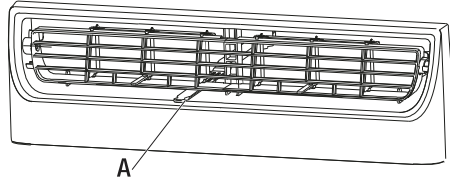

NOTE: The exhaust air vent control will function only when the fan is running.

5 Normal Sounds

When your air conditioner is operating normally, you may hear sounds such as:

- Droplets of water hitting the condenser, causing a pinging or clicking sound. The water droplets help cool the condenser.
- Air movement from the fan.
- Clicks from the thermostat cycle.
- Vibrations or noise due to poor wall or window construction.
- A high-pitched hum or pulsating noise caused by the modern high-efficiency compressor cycling on and off.

Care and Cleaning

Your new air conditioner is designed to give you many years of dependable service. This section tells you how to clean and care for your air conditioner properly. Call your local authorized dealer for an annual checkup. Remember the cost of this service call is your responsibility.

CLEANING THE AIR FILTER

The air filter is removable for easy cleaning. A clean filter helps remove dust, lint, and other particles from the air and is important for best cooling and operating efficiency. Check the filter every 2 weeks to see whether it needs cleaning.



NOTE: Do not operate the air conditioner without the filter in place.

- Turn off the air conditioner.
- Open the front panel. Grasp the filter by the handle and pull it out.

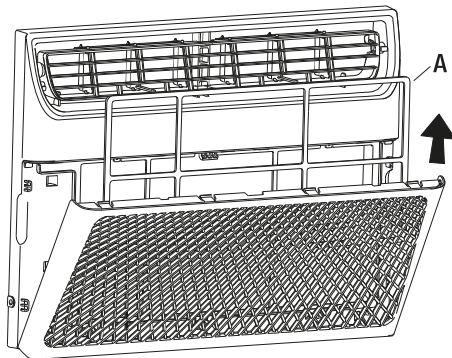

- Use a vacuum cleaner to clean the air filter. If the air filter is very dirty, wash it in warm water with a mild detergent. Do not wash the air filter in the dishwasher or use any chemical cleaners. Air dry the filter completely before replacing to ensure maximum efficiency.
- Replace the air filter back into the air conditioner.

CLEANING THE FRONT PANEL

- Turn off the air conditioner.
- Clean the front panel with a soft, damp cloth.
- Air dry the front panel completely.

REPAIRING PAINT DAMAGE

Check once or twice a year for paint damage. This is very important, especially in areas near oceans or where rust is a problem. If needed, touch up with a good grade enamel paint.



ANNUAL MAINTENANCE

Your air conditioner needs annual maintenance to help ensure steady, top performance throughout the year. Call your local authorized dealer to schedule an annual checkup. The expense of an annual inspection is your responsibility.

REMOVING AC FROM WINDOW

- Turn AC off, and disconnect power cord.
- Remove sash seal from between windows and unscrew safety lock.
- Remove screws installed through frame and frame lock. Remove the EVA foam (E-star models only).
- Close the curtain housing.
- Keeping a firm grip on air conditioner, raise sash and carefully remove.
- Be careful not to spill any standing water while lifting unit from window. Store parts with the AC.

Troubleshooting

Problem	Solution
Air conditioner will not operate	<div style="border: 1px solid black; padding: 5px; margin-bottom: 10px;"> <p>DANGER: ELECTRICAL SHOCK HAZARD</p> <ul style="list-style-type: none"> <input type="checkbox"/> Plug into a grounded 3-prong outlet. <input type="checkbox"/> Do not remove ground prong. <input type="checkbox"/> Do not use an adapter. <input type="checkbox"/> Do not use an extension cord. <input type="checkbox"/> Failure to follow these instructions can result in death, fire, or electrical shock. </div>  <ul style="list-style-type: none"> <input type="checkbox"/> The power supply cord is unplugged. Plug into grounded 3-prong outlet. See "Electrical Requirements". <input type="checkbox"/> The power supply cord has tripped. <input type="checkbox"/> A household fuse has blown, or circuit breaker has tripped. Replace the fuse or reset the circuit breaker. If the problem continues, call an electrician. See "Electrical Requirements". <input type="checkbox"/> The Power button has not been pressed. Press the Power button. <input type="checkbox"/> The local power has failed. Wait for power to be restored.
Air conditioner blows fuses or trips circuit breakers	<ul style="list-style-type: none"> <input type="checkbox"/> Too many appliances are being used on the same circuit. Unplug or relocate appliances that share the same circuit. <input type="checkbox"/> Time-delay fuse or circuit breaker of the wrong capacity is being used. Replace with a time-delay fuse or circuit breaker of the correct capacity. See "Electrical Requirements". <input type="checkbox"/> An extension cord is being used. Do not use an extension cord with this or any other appliance. <input type="checkbox"/> You are trying to restart the air conditioner too soon after turning off the air conditioner. Wait at least 3 minutes after turning off the air conditioner before trying to restart the air conditioner.
Air conditioner power supply cord trips	<ul style="list-style-type: none"> <input type="checkbox"/> Disturbances in your electrical current can trip <input type="checkbox"/> Electrical overloading, overheating, cord pinching or aging can trip <div style="border: 1px solid black; padding: 5px; margin-top: 10px;">  <p>NOTE: The supply cord must be replaced by the manufacturer, its service agent or similarly qualified persons in order to avoid a hazard.</p> </div>

Troubleshooting

Problem	Solution
Air conditioner seems to run too much	<ul style="list-style-type: none"> <input type="checkbox"/> The current air conditioner replaced an older model. The use of more efficient components may cause the air conditioner to run longer than an older model, but the total energy consumption will be less. Newer air conditioners do not emit the “blast” of cold air you may be accustomed to from older air conditioners, but this is not an indication of lesser cooling capacity or efficiency. Refer to the efficiency rating (EER) and capacity rating (in Btu/h) marked on the air conditioner. <input type="checkbox"/> The air conditioner is in a heavily occupied room, or heat producing appliances are in use in the room. Use exhaust vent fans while cooking or bathing and try not to use heat producing appliances during the hottest part of the day. A higher capacity air conditioner may be required, depending on the size of the room being cooled.
Air conditioner cycles on and off too much or does not cool	<ul style="list-style-type: none"> <input type="checkbox"/> The air conditioner is not properly sized for your room. Check the cooling capabilities of your room air conditioner. Room air conditioners are not designed to cool multiple rooms. <input type="checkbox"/> The filter is dirty or obstructed by debris. Clean the filter. <input type="checkbox"/> The inside evaporator and outside condenser coils are dirty or obstructed by debris. See Annual Maintenance. <input type="checkbox"/> There is excessive heat or moisture (open container cooking, showers, etc.) in the room. Use a fan to exhaust heat or moisture from the room. Try not to use heat producing appliances during the hottest part of the day. <input type="checkbox"/> The louvers are blocked. Install the air conditioner in a location where the louvers are free from curtains, blinds, furniture, etc. <input type="checkbox"/> The temperature of the room you are trying to cool is extremely hot. Allow extra time for the air conditioner to cool off a very hot room. <input type="checkbox"/> Windows or doors to the outside are open. Close all windows and doors. <input type="checkbox"/> The Temp control is not at a cool enough setting. Adjust the Temp control to a cooler setting by pressing the minus button to reduce the temperature. Set the Fan Speed control to the highest setting.
Water drips from cabinet into your house	<ul style="list-style-type: none"> <input type="checkbox"/> The air conditioner is not properly leveled. The air conditioner should slope slightly downward toward the outside. Level the air conditioner to provide a downward slope toward the outside to ensure proper drainage. See the Installation Instructions. <div style="border: 1px solid black; padding: 5px; margin-top: 10px;">  NOTE: Do not drill a hole in the bottom of the metal base and condensate pan. </div>

Troubleshooting

Error Codes

If you encounter a problem with you unit and the compressor stops running, please do the following steps for the unit to display the error and know the type of problem:

- Turn on your Air Conditioner unit
- On your remote controller, press the **DIMMER/SLEEP button** repeatedly for four (4) times in 10 seconds
- Once successful, the front panel LED will display one of the error codes stated below

Error code	Type of Error	The root cause is may be one of the following
0	Normal	
1	The failure for temperature sensor of outdoor coil	<p>a. The outdoor temperature sensor is loose;</p> <p>b. the outdoor temperature sensor is experiencing failure</p> <p>c. The indoor control board is experiencing failure</p>
2	Compressor exhaust temperature sensor in trouble	<p>a. the compressor exhaust temperature sensor connection is loose;</p> <p>b. the compressor exhaust temperature sensor is experiencing failure</p> <p>c. the condenser control board is experiencing failure</p>
5	IPM module protection	<p>a. The IPM board is experiencing failure.</p> <p>b. The condenser fan is broken;</p> <p>c. The condenser fan motor is failure.</p> <p>d. The condenser fan has been blocked;</p> <p>e. The condenser is dirty;</p>
6	AC voltage higher or lower protection	<p>a. the supply voltage is higher or lower than normal;</p> <p>b. the inner supply voltage of the unit is higher or lower than normal</p>
7	Communication failure between the indoor unit and outdoor unit	<p>a. the communication cable connect is loose;</p> <p>b. the communication cable is failure;</p> <p>c. the connection between the filter board and the condenser control board is incorrect or loose;</p> <p>d. the connection between the filter board and the terminal is incorrect or loose;</p> <p>e. the evaporator control board is failure;</p> <p>f. the PFC board is failure;</p> <p>g. the power board is failure;</p> <p>h. the condenser control board is failure.</p>

Troubleshooting

8	Current overload protection	<ul style="list-style-type: none"> a. the fan motor runs abnormally; b. the condenser and evaporator is dirty; c. the air inlet and outlet is abnormally
9	Maximum current protection	<ul style="list-style-type: none"> a. the outdoor control board is short circuit; b. the drive board is short circuit; c. the other components is short circuit
10	Communication trouble between outdoor unit and driver	<ul style="list-style-type: none"> a. the connection wires connect loose b. the outdoor board or drive board is failure;
11	Outdoor EEPROM in trouble	<ul style="list-style-type: none"> a. the EEPROM chip is loose; b. the EEPROM chip inserted with opposite direction; c. the EEPROM chip is failure
12	Outdoor ambient temperature too low or too high protection	Outdoor ambient temperature too low or too high
13	Compressor exhaust temperature too high protection	<ul style="list-style-type: none"> a. the compressor exhaust temperature sensor is failure; b. the refrigerant of the unit is not enough
14	Outdoor ambient temperature sensor in trouble	<ul style="list-style-type: none"> a. the outdoor ambient temperature sensor connect loose b. the outdoor ambient temperature sensor is failure; c. the outdoor control board is failure
15	Compressor shell temperature too high protection	<ul style="list-style-type: none"> a. the compressor exhaust temperature sensor connect loose b. the refrigerant of the unit is not enough
16	Anti-freeze protection with cooling or overload protection with heating in	<ul style="list-style-type: none"> a. the indoor coil temperature sensor connect loose; b. the indoor coil temperature sensor is failure; c. the indoor control board is failure d. the refrigerant system is abnormal.
17	PFC protection	<ul style="list-style-type: none"> a. the PFC is failure; b. the outdoor drive board is failure
18	DC compressor start failure	<ul style="list-style-type: none"> a. the outdoor drive board is failure; b. the compressor is failure
19	Compressor drive in trouble	<ul style="list-style-type: none"> a. the outdoor drive board is failure; b. the compressor is failure c. the outdoor control board is failure

Troubleshooting

20	Outdoor fan motor locked rotor protection	<ul style="list-style-type: none"> a. the connection of the outdoor fan motor is loose; b. there are something block the outdoor fan; c. the fan motor is failure; d. the outdoor control board is failure
21	Outdoor coil anti-overload protection with cooling	<ul style="list-style-type: none"> a. the refrigerant is too much; b. the outdoor fan motor is failure; c. the outdoor fan is broken; d. the condenser is dirty; e. the air inlet and air outlet of the indoor unit and the outdoor unit is not normally
22	Compressor pre heating process	it is normal mode in cold weather
23	There is a leak in the product	<ul style="list-style-type: none"> a. There is a leak in the indoor b. There is a leak in the outdoor c. There is a leak in the connecting pipe
24	Chip in outdoor board in trouble	<ul style="list-style-type: none"> a. Using the wrong drive board; b. Using the wrong compressor.
26	Overheated outdoor radiator	<ul style="list-style-type: none"> a. Radiator sensor fails b. Detection circuit of the sensor on the control panel fails
27	Protection against too high system pressure	<ul style="list-style-type: none"> a. The pressure switch fails b. The pressure detection switch on the control panel fails c. The measured value of system pressure exceeds the limit
33	The failure for temperature sensor of indoor room	<ul style="list-style-type: none"> a. The indoor room temperature sensor loose; b. The indoor room temperature sensor is failure; c. The indoor control board is failure.
34	The failure for temperature sensor of indoor coil temperature	<ul style="list-style-type: none"> a. The indoor coil temperature sensor loose; b. The indoor coil temperature sensor is failure; c. The indoor control board is failure.
36	Communication failure between the indoor unit and outdoor unit	<ul style="list-style-type: none"> a. the communication cable connect loose; b. the communication cable is failure; c. the connection between the filter board and the outdoor control board is incorrect or loose; d. the connection between the filter board and the terminal is incorrect or loose; e. the indoor control board is failure; f. the PFC board is failure; g. the power board is failure; h. the outdoor control board is failure.
38	Indoor EEPROM failure	<ul style="list-style-type: none"> a. The EEPROM chip loose; b. The indoor control board is failure

Specification

Model name	BPVOW 090	BPVOW 120
Refrigerant	R32	R32
Total Refrigerant Amount (g)	270	450
GWP	675	675
CO2 equivalent (tonnes)	0.183	0.304
Protection against electric shock	Class I	Class I
Climate Class	T1	T1
Heating Type	Cooling Only	Cooling Only
Cooling Capacity (Btu/h)	8530	11396
Cooling Capacity (kW)	2.5	3.34
Heating Capacity (Btu/h)	/	/
Heating Capacity (kW)	/	/
Energy Efficiency Cooling (W/W)	4.01	4.01
Energy Efficiency Heating (W/W)	/	/
Energy Level-Cooling	Five Star	Five Star
Energy Level-Heating	/	/
Cooling Power Input (kW)	0.86	1.06
Heating Power Input (kW)	/	/
Cooling Running Current (A)	3.9	6.8
Heating Running Current (A)	/	/
Voltage/Frequency/Phase (V/H/Ph)	230V~,60Hz/1 Ph	230V~,60Hz/1 Ph
Noise Pressure Level (dBA)	54/52/50	56/54/52
Air flow volume (m3/h)	450/400/350	500/450/380
Rated Power Input (W)	980	1200
Rated Current Input (A)	5.6	7.0
Power Supply Cord specification	6-15P/16AWG 1.31x3mm2	6-15P/16AWG 1.31x3mm2
Unit Net Dimension (WxHxD) mm	480×370×545	480×370×545
Unit Net Weight (kg)	20.5	24

Note:

1. Specifications are standard values calculated based on rated operating conditions, They will vary in difference work condition.
2. Rated cooling values are calculated under 35/24 (In.) 27/19 (Out.) condition.
3. Rated heating values are calculated under 20/15 (In.) 7/6 (Out.) condition. (For Heat pump model only)

Beko Pilipinas Corporation
Unit 10A, Net Lima 55th Ave. Corner 26th Street,
E-Square Crescent Park West,
Bonifacio Global City, Taguig 1634
Toll Free: 1800-10-888-2356
Mobile: 0917-515-2356
www.beko.ph